

INSPECTION

NOTICE:

When using a vise, do not overtighten it.

1. INSPECT STEERING RACK

- (a) Using a dial indicator, check the rack for runout, teeth wear and damage.

Maximum runout: 0.1 mm (0.004 in.)

- (b) Check the back surface for wear and damage.

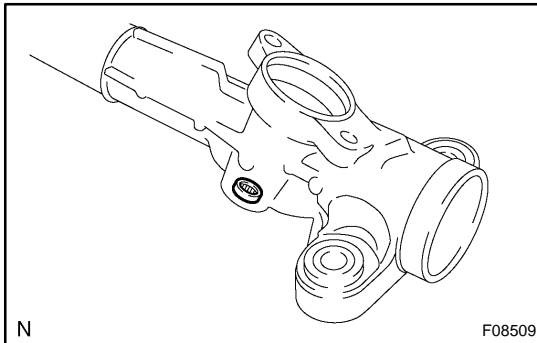

2. INSPECT BEARING

- (a) Check the needle roller bearing for pitmarks or damage. If faulty, replace the rack housing.

- (b) Coat the inside of the bearing with molybdenum disulfide lithium base grease.