

# Taillight Control Relay Circuit

## CIRCUIT DESCRIPTION

When the theft deterrent system is activated, it causes the Tr in the ECU to switch ON and OFF at approximately 0.4 sec. intervals. This switches the taillight control relay ON and OFF, thus flashing the taillights (See the wiring diagram below).

In this condition, if any of the following operations is done, the Tr in the ECU goes OFF and the taillight control relay switches OFF, thus stopping the taillights flashing:

- (1) Unlock the front LH or RH door with a key.
- (2) Turn the ignition switch to IG or ON position.
- (3) Unlock the doors with the wireless door lock control system.
- (4) Wait for approximately 60 seconds.

## WIRING DIAGRAM

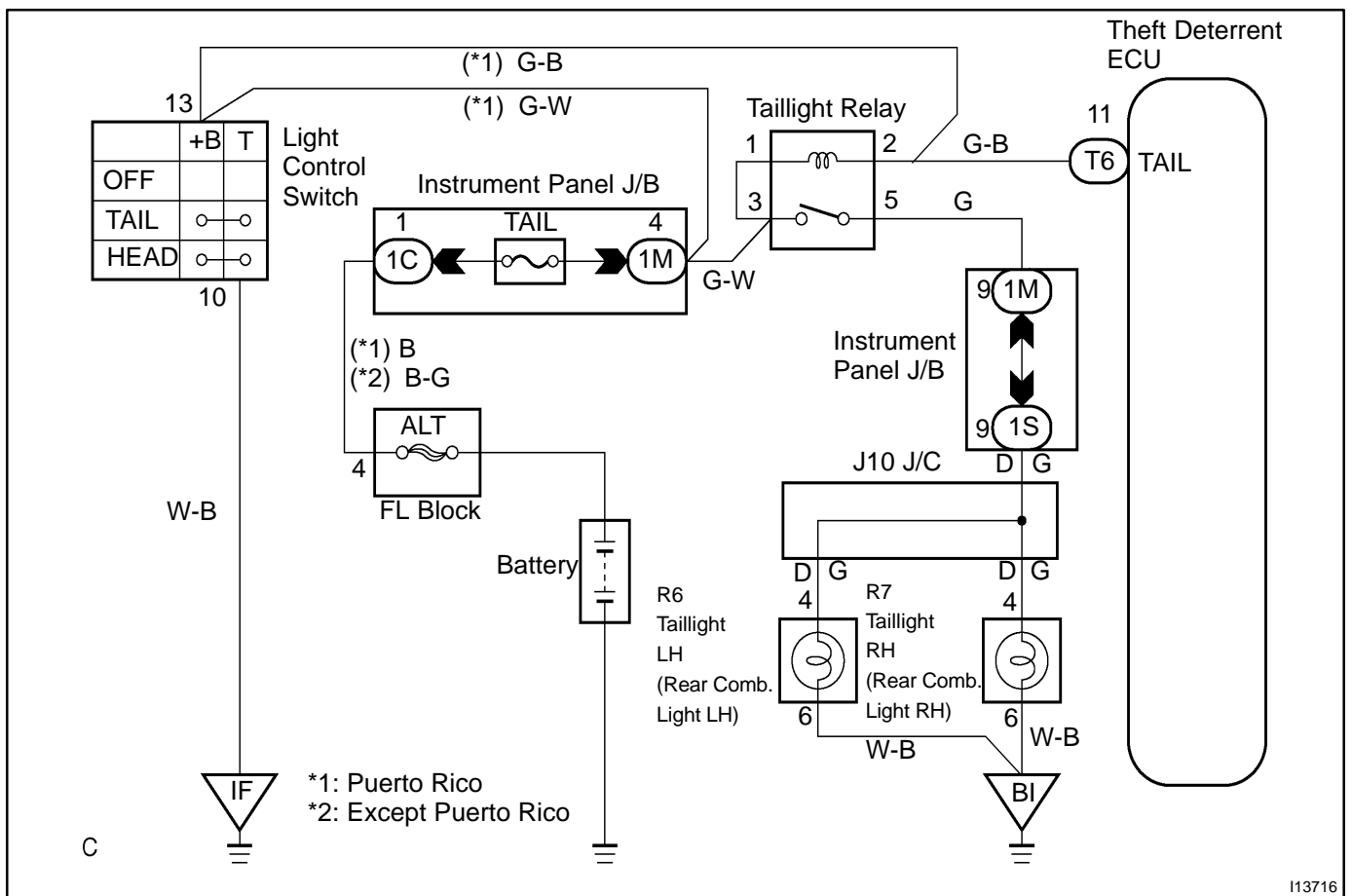

I13716

## INSPECTION PROCEDURE

### HINT:

The flow chart below is based on the premise that the taillights light up normally whenever the light control switch is operated. If taillight operation is not normal when the light control switch is operated, proceed to troubleshooting on page [BE-2](#).

- |          |  |
|----------|--|
| <b>1</b> | <b>Check voltage between terminal TAIL of theft deterrent ECU connector and body ground.</b> |
|----------|--|

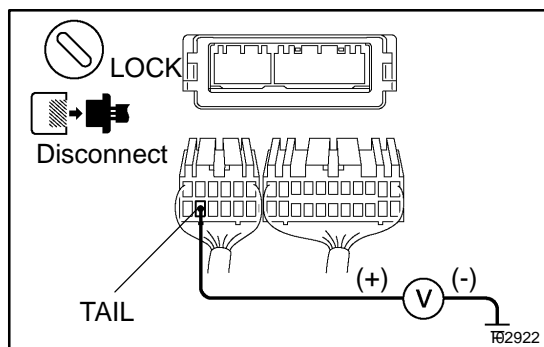

### PREPARATION:

- (a) Remove the glove compartment door.
- (b) Disconnect the theft deterrent ECU connector.

### CHECK:

Measure voltage between terminal TAIL of theft deterrent ECU connector and body ground.

### OK:

**Voltage: 10 - 14 V**

**NG**

**Check and repair harness and connector between theft deterrent ECU and taillight control relay (See page [IN-29](#)).**

**OK**

**Check and replace theft deterrent ECU.**