

PRE-CHECK

1. DIAGNOSIS SYSTEM

(a) Description

- When troubleshooting OBDII vehicles, the only difference from the usual troubleshooting procedure is that you connect to the vehicle the OBDII scan tool complying with SAE J1978 or TOYOTA hand-held tester, and read off various data output from the vehicle's ECM.
- OBDII regulations require that the vehicle's on-board computer lights up the Malfunction Indicator Lamp (MIL) on the instrument panel when the computer detects a malfunction in the emission control system/components or in the powertrain control components which affect vehicle emissions, or a malfunction in the computer. In addition to the MIL lighting up when a malfunction is detected, the applicable Diagnostic Trouble Code (DTC) prescribed by SAE J2012 are recorded in the ECM memory (See page [DI-14](#)).

If the malfunction does not reoccur in 3 consecutive trips, the MIL goes off automatically but the DTCs remain recorded in the ECM memory.

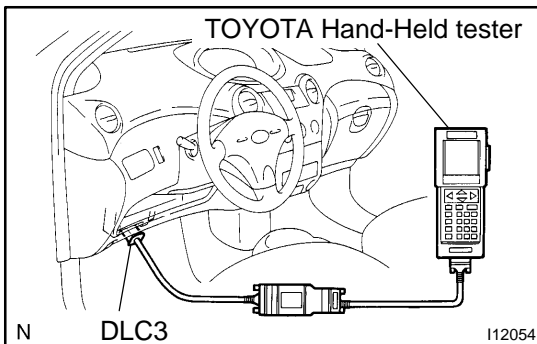

- To check the DTCs, connect the TOYOTA hand-held tester or OBDII scan tool to Data Link Connector 3 (DLC3) on the vehicle. The TOYOTA hand-held tester or OBDII scan tool also enables you to erase the DTCs and check frozen frame data and various forms of engine data. (For operating instructions, see the OBDII scan tool's instruction book.)
- DTCs include SAE controlled codes and manufacturer controlled codes. SAE controlled codes must be set as prescribed by the SAE, while manufacturer controlled codes can be set freely by the manufacturer within the prescribed limits (See DTC chart on page [DI-14](#)).

- The diagnosis system operates in normal mode during normal vehicle use. It also has a check mode for technicians to simulate malfunction symptoms and troubleshoot. Most DTCs use 2 trip detection logic* to prevent erroneous detection, and ensure thorough malfunction detection. By switching the ECM to check mode when troubleshooting, the technician can cause the MIL to light up for a malfunction that is only detected once or momentarily (TOYOTA hand-held tester only). (See step 2)
- *2 trip detection logic:
When a malfunction is first detected, the malfunction is temporarily stored in the ECM memory (1st trip).

If the same malfunction is first detected again during the second drive test, this second detection causes the MIL to light up (2nd trip) (However, the IG switch must be turned OFF between the 1st trip and the 2nd trip.).

- Freeze frame data:
Freeze frame data records the engine condition when a misfire (DTC P0300 - P0304) or fuel trim malfunction (DTC P0171) or other malfunction (first malfunction only), is detected.
- Because freeze frame data records the engine conditions (fuel system, calculated load, engine coolant temperature, fuel trim, engine speed, vehicle speed, etc.) when the malfunction is detected, when troubleshooting it is useful for determining whether the vehicle was running or stopped, the engine warmed up or not, the air-fuel ratio lean or rich, etc. at the time of the malfunction.

Priorities for troubleshooting:

If troubleshooting priorities for multiple DTCs are given in the applicable DTC chart, these should be followed.

If no instructions are given troubleshoot DTCs according to the following priorities.

- (1) DTCs other than fuel trim malfunction (DTC P0171, P0172), and misfire (DTC P0300 - P0304).
- (2) Fuel trim malfunction (DTC P0171).
- (3) Misfire (DTC P0300 - P0304).

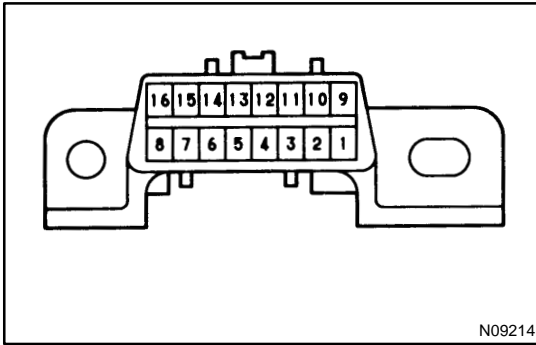

- (b) Check the DLC3.
The vehicle's ECM uses ISO 9141-2 for communication. The terminal arrangement of DLC3 complies with SAE J1962 and matches the ISO 9141-2 format.

Terminal No.	Connection / Voltage or Resistance	Condition
7	Bus ⊕ Line / Pulse generation	During transmission
4	Chassis Ground / ↔ Body Ground 1 Ω or less	Always
5	Signal Ground / ↔ Body Ground 1 Ω or less	Always
16	Battery Positive / ↔ Body Ground 9 - 14 V	Always

HINT:

If your display shows "UNABLE TO CONNECT TO VEHICLE" when you have connected the cable of the TOYOTA hand-held tester or OBDII scan tool to DLC3, turned the ignition switch ON and operated the scan tool, there is a problem on the vehicle side or tool side.

- If communication is normal when the tool is connected to another vehicle, inspect DLC3 on the original vehicle.
- If communication is still not possible when the tool is connected to another vehicle, the problem is probably in the tool itself, so consult the Service Department listed in the tool's instruction manual.

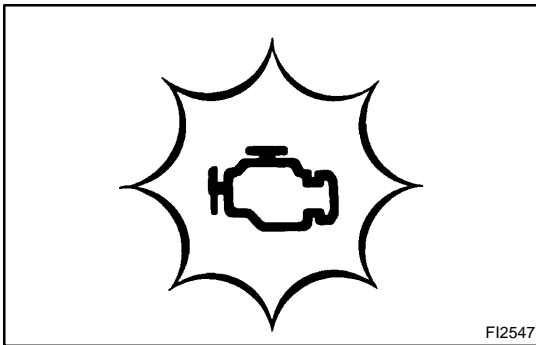
**2. INSPECT DIAGNOSIS (Normal Mode)**

- (a) Check the MIL
(1) The MIL comes on when the ignition switch is turned ON and the engine is not running.

HINT:

If the MIL does not light up, troubleshoot the combination meter (See page [BE-47](#)).

- (2) When the engine started, the MIL should go off. If the lamp remains on, the diagnosis system has detected a malfunction or abnormality in the system.

- (b) Check the DTC.

NOTICE:

- If there is no DTC in the normal mode, check the 1st trip DTC using Continuous Test Result function (Mode 7 for SAE J1979) or the TOYOTA hand-held tester or OBDII scan tool.

- **TOYOTA hand-held tester only:**
When the diagnosis system is switched from normal mode to check mode, it erases all DTCs and freezed frame data recorded in normal mode. So before switching modes, always check the DTCs and freezed frame data, and note them down.
 - (1) Prepare the TOYOTA hand-held tester or OBDII scan tool (complying with SAE J1978).
 - (2) Connect the TOYOTA hand-held tester or OBDII scan tool to DLC3 under the instrument panel lower pad.
 - (3) Turn the ignition switch ON and turn the TOYOTA hand-held tester or OBDII scan tool switch ON.
 - (4) Use the TOYOTA hand-held tester or OBDII scan tool to check the DTCs and freezed frame data; note them down. (For operating instructions, see the OBDII scan tool's instruction book.)
 - (5) See step 4 to confirm the details of the DTCs.

NOTICE:

- **When simulating symptoms with an OBDII scan tool (excluding TOYOTA hand-held tester) to check the DTCs, use normal mode. For code on the DTC chart subject to "2 trip detection logic", perform the following either action.**
- **Turn the ignition switch OFF after the symptom is simulated the first time. Then repeat the simulation process again. When the problem has been simulated twice, the MIL lights up and the DTCs are recorded in the ECM.**
- **Check the 1st trip DTC using Mode 7 (Continuous Test Results) for SAE J1979.**

(c) Clear the DTC.

The DTCs and freezed frame data will be erased by either action.

- (1) Operating the TOYOTA hand-held tester or OBDII scan tool (complying with SAE J1978) to erase the codes. (See the OBDII scan tool's instruction book for operating instructions.)
- (2) Disconnecting the battery terminals or EFI fuse.

NOTICE:

If the TOYOTA hand-held tester switches the ECM from the normal mode to the check mode or vice-versa, or if the ignition switch is turned from ON to ACC or OFF during check mode, the DTCs and freezed frame data will be erased.

3. INSPECT DIAGNOSIS (Check Mode)

HINT:

TOYOTA hand-held tester only:

Compared to the normal mode, the check mode has an increased sensitivity to detect malfunctions.

Furthermore, the same diagnostic items which are detected in the normal mode can also be detected in the check mode.

Check the DTC.

- (1) Initial conditions:
 - Battery positive voltage 11 V or more.
 - Throttle valve fully closed.
 - Transmission in "P" or "N" position.
 - A/C switched OFF.
- (2) Turn the ignition switch OFF.
- (3) Prepare the TOYOTA hand-held tester.
- (4) Connect the TOYOTA hand-held tester to DLC3 under the instrument panel lower pad.
- (5) Turn the ignition switch ON and switch the TOYOTA hand-held tester ON.
- (6) Switch the TOYOTA hand-held tester normal mode to check mode (Check that the MIL flashes.).

NOTICE:

If the TOYOTA hand-held tester switches the ECM from the normal mode to the check mode or vice-versa, or if the ignition switch is turned from ON to ACC or LOCK during check mode, the DTCs and frozen frame data will be erased.

- (7) Switch the engine. (The MIL goes out after the engine start.)
- (8) Simulate the conditions of the malfunction described by the customer.

NOTICE:

Leave the ignition switch ON until you have checked the DTC, etc.

- (9) After simulating the malfunction conditions, use the TOYOTA hand-held tester diagnosis selector to check the DTCs and frozen frame data, etc.

HINT:

Take care not to turn the ignition switch OFF. Turning the ignition switch OFF switches the diagnosis system from check mode to normal mode. so all DTCs, etc. are erased.

- (10) After checking the DTC, inspect the applicable circuit.

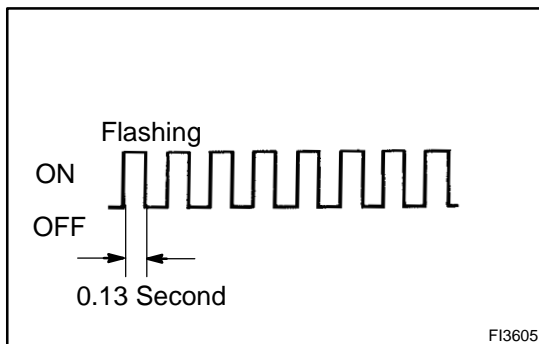

4. FAIL-SAFE CHART

If any of the following codes is recorded, the ECM enters fail-safe mode.

DTC No.	Fail-Safe Operation	Fail-Safe Deactivation Conditions
P0100	Ignition timing fixed at 5° BTDC	Returned to normal condition
P0110	Intake air temp. is fixed at 20°C (68°F)	Returned to normal condition

P0115	Engine coolant temp. is fixed at 80°C (176°F)	Returned to normal condition
P0120	VTA is fixed at 0°	The following condition must be repeated at least 2 times consecutively $0.1\text{ V} \leq \text{VTA} \leq 0.95\text{ V}$
P0135 P0141	The heater circuit in which an abnormality is detected is turned off	Ignition switch OFF
P0325	Max. timing retardation	Ignition switch OFF
P1300 P1305 P1310 P1315	Fuel cut	IGF signal is detected for 2 consecutive ignitions

5. CHECK FOR INTERMITTENT PROBLEMS

HINT:

TOYOTA hand-held tester only:

By putting the vehicle's ECM in check mode, 1 trip detection logic is possible instead of 2 trip detection logic and sensitivity to detect open circuits is increased. This makes it easier to detect intermittent problems.

- Clear the DTC (See step 3).
- Set the check mode (See step 3).
- Perform a simulation test (See page [IN-19](#)).
- Check the connector and terminal (See page [IN-29](#)).
- Handle the connector (See page [IN-29](#)).

6. BASIC INSPECTION

When the malfunction code is not confirmed in the DTC check, troubleshooting should be performed in the order for all possible circuits to be considered as the causes of the problems. In many cases, by carrying out the basic engine check shown in the following flow chart, the location causing the problem can be found quickly and efficiently. Therefore, use of this check is essential in engine troubleshooting.

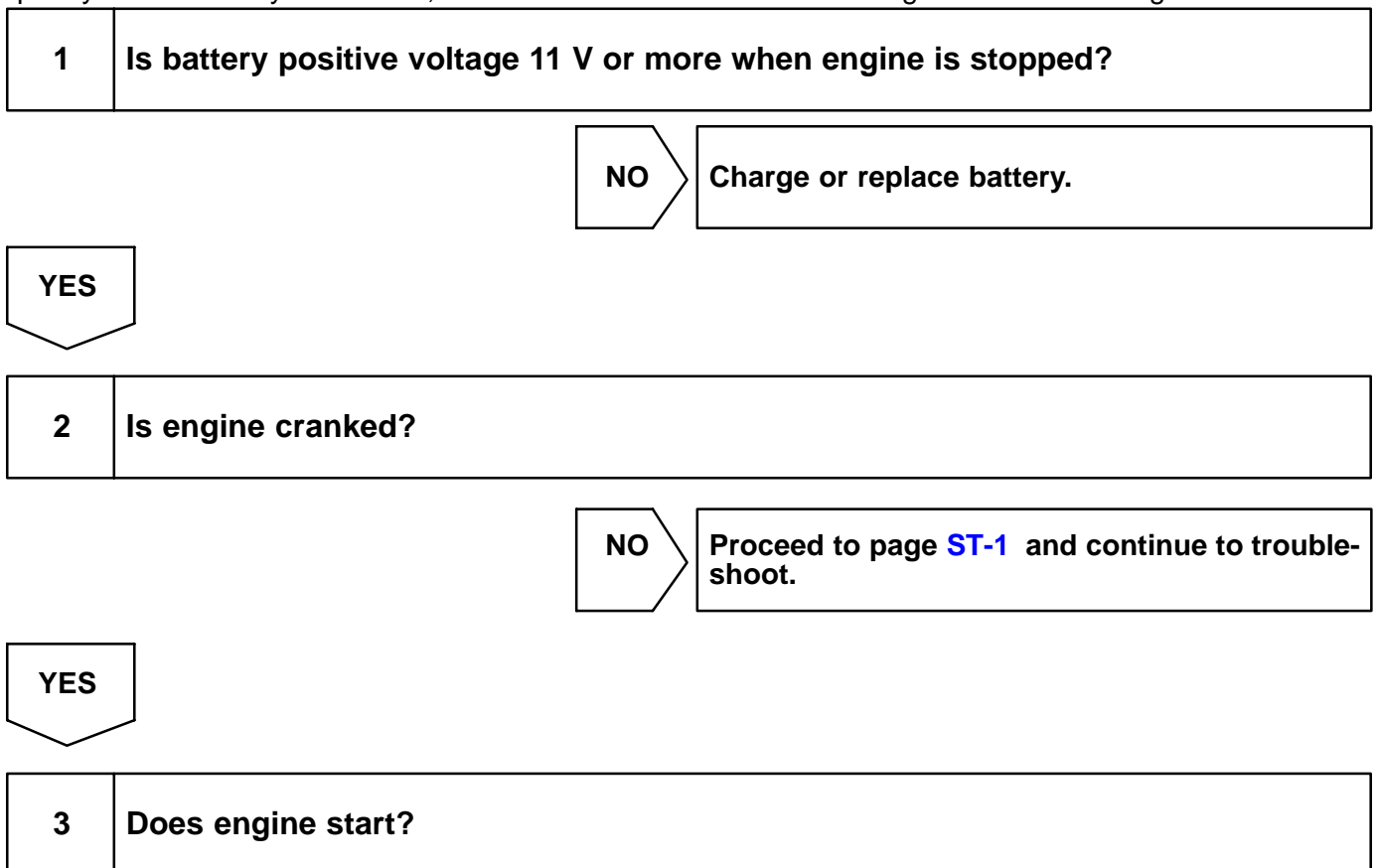

NO Go to step 7.

YES

4 Check air filter.

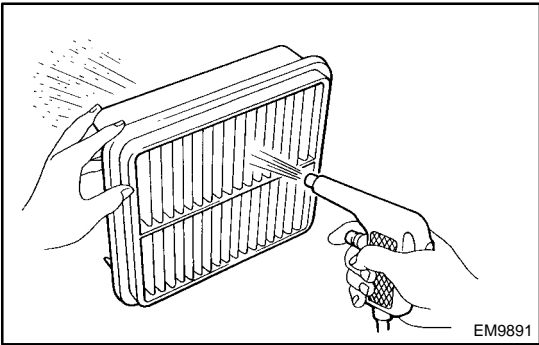

PREPARATION:
Remove the air filter.
CHECK:
Visual check that the air filter is not dirty or excessive oily.
HINT:
If necessary, clean the air filter with compressed air. First blow from inside thoroughly, then blow from outside of the air filter.

NG Repair or replace.

OK

5 Check engine idle speed.

PREPARATION:
(a) Warm up engine to normal operating temperature.
(b) Switch off all accessories.
(c) Switch off A/C.
(d) Shift transmission into N position.
(e) Connect the TOYOTA hand-held tester or OBDII scan tool to DLC3 on the vehicle.

CHECK:
Use CURRENT DATA to check the idle speed.

OK:
Idle speed:
M/T 600 - 700 rpm
A/T 650 - 750 rpm

NG Proceed to problem symptoms table on page [DI-21](#) .

OK

6 Check ignition timing.

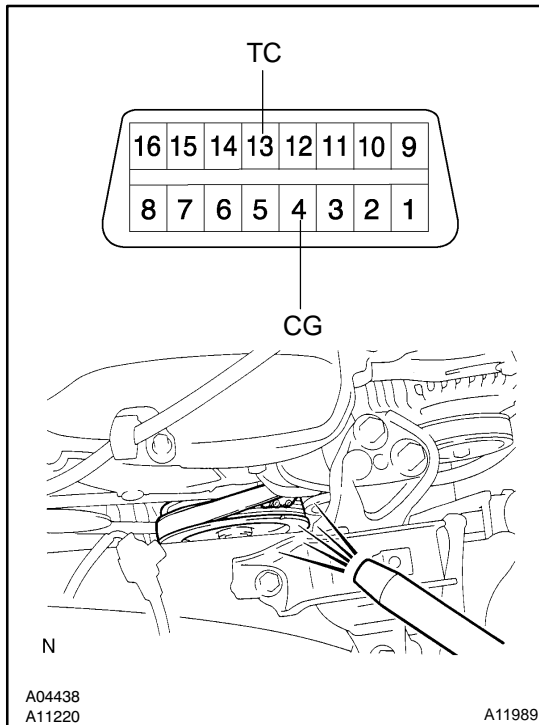

PREPARATION:

- Warm up engine to normal operating temperature.
- Shift transmission into N position.
- Keep the engine speed at idle.
- Using SST, connect terminals TE1 and E1 of DLC1.
SST 09843-18020
- Using a timing light, connect the tester to the ignition coil connector wire (See page [EM-1 1](#)).

CHECK:

Check ignition timing.

OK:

Ignition timing: 8 - 12° BTDC at idle

NG

Proceed to page [IG-1](#) and continue to troubleshoot.

OK

Proceed to problem symptoms table on page [DI-21](#).

7 Check fuel pressure.

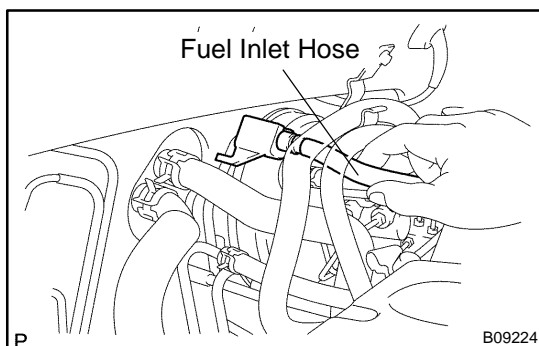

PREPARATION:

- Be sure that enough fuel is in the tank.
- Connect the TOYOTA hand-held tester to the DLC3.
- Turn the ignition switch ON and push the TOYOTA hand-held tester main switch ON.
- Use the ACTIVE TEST mode to operate the fuel pump.
- Please refer to the TOYOTA hand-held tester operator's manual for further details.
- If you have no TOYOTA hand-held tester, connect the positive (+) and negative (-) leads from the battery to the fuel pump connector (See page [SF-6](#)).

CHECK:

Check for fuel pressure in the fuel inlet hose when it is pinched off.

HINT:

At this time, you will hear a fuel flowing noise.

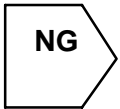

Proceed to page [SF-6](#) and continue to trouble-shoot.

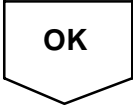

8	Check for spark.
----------	-------------------------

PREPARATION:

- (a) Remove the ignition coil (See page [IG-5](#)).
- (b) Remove the spark plug.
- (c) Install the spark plug to ignition coil and connect the ignition coil connector to ignition coil.
- (d) Disconnect the injector connector.
- (e) Be sure to ground the screw of the spark plug securely.

CHECK:

Check if spark occurs while engine is being cranked.

NOTICE:

- Do not crash the electrode gap.
- To prevent excess fuel being injected from the injectors during this test, don't crank the engine for more than 5 - 10 seconds at a time.

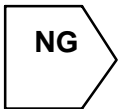

Proceed to page [IG-1](#) and continue to trouble-shoot.



Proceed to problem symptoms table on page [DI-21](#) .

7. ENGINE OPERATING CONDITION

NOTICE:

The values given below for "Normal Condition" are representative values, so a vehicle may still be normal even if its value varies from those listed here. So do not decide whether a part is faulty or not solely according to the "Normal Condition" here.

(a) CARB mandated signals.

TOYOTA hand-held tester display	Measurement Item	Normal Condition*
FUEL SYS #1	Fuel System Bank 1 OPEN: Air-fuel ratio feedback stopped CLOSED: Air-fuel ratio feedback operating	Idling after warming up: CLOSED
CALC LOAD	Calculator Load: Current intake air volume as a proportion of max. intake air volume	Idling: 10.0 - 30.0 % Racing without load (2,500rpm): 10.0 - 30.0 %
COOLANT TEMP.	Engine Coolant Temp. Sensor Value	After warming up: 80 - 95°C (176 - 203°F)
SHORT FT #1	Short-term Fuel Trim Bank 1	0 ± 20%
LONG FT #1	Long-term Fuel Trim Bank 1	0 ± 20%
ENGINE SPD	Engine Speed	Idling: MT 600 - 700 rpm AT 650 - 750 rpm
VEHICLE SPD	Vehicle Speed	Vehicle Stopped: 0 km/h (0 mph)
IGN ADVANCE	Ignition Advance: Ignition Timing of Cylinder No. 1	Idling: BTDC 0 - 14°
INTAKE AIR	Intake Air Temp. Sensor Value	Equivalent to Ambient Temp.
MAF/AFM	Air Flow Rate Through Mass Flow Meter	Idling: 1.0 - 3.0 gm/sec. Racing without load (2,500 rpm): 3.0 - 8.0 gm/sec.
THROTTLE POS	Voltage Output of Throttle Position Sensor Calculated as a percentage: 0 V → 0%, 5 V → 100%	Throttle Fully Closed: 0 - 5 % Throttle Fully Open: 90 - 100 %
O2S B1, S1	Voltage Output of Heated Oxygen Sensor Bank 1, Sensor 1	Idling: 0.1 - 0.9 V
O2FT B1, S1	Heated Oxygen Sensor Fuel Trim Bank 1, Sensor 1 (Same as SHORT FT #1)	0 ± 20 %
O2S B1, S2	Voltage Output of Heated Oxygen Sensor Bank 1, Sensor 2	Driving at 50 km/h (31 mph): 0.1 - 0.9 V

*: If no conditions are specifically stated for "Idling", it means the shift lever is at N or P position, the A/C switch is OFF and all accessory switches are OFF.

(b) TOYOTA Enhanced Signals.

TOYOTA hand-held tester display	Measurement Item	Normal Condition*
MISFIRE RPM	Engine RPM for first misfire range	Misfire 0: 0 rpm
MISFIRE LOAD	Engine load for first misfire range	Misfire 0: 0 g/r
INJECTOR	Fuel injection time for cylinder No.1	Idling: 1.0 - 3.0 ms
IAC DUTY RATIO	Intake Air Control Valve Duty Ratio Opening ratio rotary solenoid type IAC valve	Idling: 20 - 40 %
STARTER SIG	Starter Signal	Cranking: ON
A/C SIG	A/C Switch Signal	A/C ON: ON
PNP SIG	Park/Neutral Position Switch Signal	P or N position: ON
STOP LIGHT SW	Stop Light Switch Signal	Stop light switch ON: ON
FC IDL	Fuel Cut Idle: Fuel cut when throttle valve fully closed, during deceleration	Fuel cut operating: ON
FC TAU	Fuel Cut TAU: Fuel cut during very light load	Fuel cut operating: ON

DIAGNOSTICS - ENGINE

CYL#1, CYL#2, CYL#3, CYL#4	Abnormal revolution variation for each cylinder	0 %
IGNITION	Total number of ignition for every 1,000 revolutions	0 - 2,000
FUEL PUMP	Fuel Pump Signal	Idling: ON
EVAP (PURGE) VSV	EVAP VSV Signal	VSV operating: ON
VAPOR PRESS VSV	Vapor Pressure VSV Signal	VSV operating: ON
TOTAL FT B1	Total Fuel Trim Bank 1: Average value for fuel trim system of bank 1	Idling: 0.8 - 1.2 V
O2 LR B1, S1 *	Heated Oxygen Sensor Lean Rich Bank 1, Sensor 1 Response time for oxygen sensor output to switch from lean to rich	Idling after warmed up: 0 - 1,000 msec.
O2 RL B1, S1 *	Heated Oxygen Sensor Rich Lean Bank 1, Sensor 1 Response time for oxygen sensor output to switch from rich to lean	Idling after warmed up: 0 - 1,000 msec.

*: If no conditions are specifically stated for "Idling", it means the shift lever is at N or P position, the A/C switch is OFF and all accessory switches are OFF.