

|            |              |                                           |
|------------|--------------|-------------------------------------------|
| <b>DTC</b> | <b>P1300</b> | <b>Igniter Circuit Malfunction (No.1)</b> |
|------------|--------------|-------------------------------------------|

|            |              |                                           |
|------------|--------------|-------------------------------------------|
| <b>DTC</b> | <b>P1305</b> | <b>Igniter Circuit Malfunction (No.2)</b> |
|------------|--------------|-------------------------------------------|

|            |              |                                           |
|------------|--------------|-------------------------------------------|
| <b>DTC</b> | <b>P1310</b> | <b>Igniter Circuit Malfunction (No.3)</b> |
|------------|--------------|-------------------------------------------|

|            |              |                                           |
|------------|--------------|-------------------------------------------|
| <b>DTC</b> | <b>P1315</b> | <b>Igniter Circuit Malfunction (No.4)</b> |
|------------|--------------|-------------------------------------------|

### CIRCUIT DESCRIPTION

A DIS (Direct Ignition System) has been adopted. The DIS improves the ignition timing accuracy, reduces high-voltage loss, and enhances the overall reliability of the ignition system by eliminating the distributor. The DIS is a 1-cylinder ignition system which ignites one cylinder with one ignition coil. In the 1-cylinder ignition system, the one spark plug is connected to the end of the secondary winding. High voltage generated in the secondary winding is applied directly to the spark plug. The spark of the spark plug pass from the center electrode to the ground electrode.

The ECM determines ignition timing and outputs the ignition signals (IGT) for each cylinder. Based on IGT signals, the power transistors in the igniter cuts off the current to the primary coil in the ignition coil is supplied to the spark plug that are connected to the end of the secondary coil. At the same time, the igniter also sends an ignition confirmation signal (IGF) as a fail-safe measure to the ECM.

| DTC No.                          | DTC Detecting Condition                      | Trouble Area                                                                                                                                                                                                               |
|----------------------------------|----------------------------------------------|----------------------------------------------------------------------------------------------------------------------------------------------------------------------------------------------------------------------------|
| P1300<br>P1305<br>P1310<br>P1315 | No IGF signal to ECM while engine is running | <ul style="list-style-type: none"> <li>• Ignition system</li> <li>• Open or short in IGF1 and IGT1 - 4 circuit from ignition coil with igniter</li> <li>• No.1 - No.4 ignition coil with igniter</li> <li>• ECM</li> </ul> |

# WIRING DIAGRAM

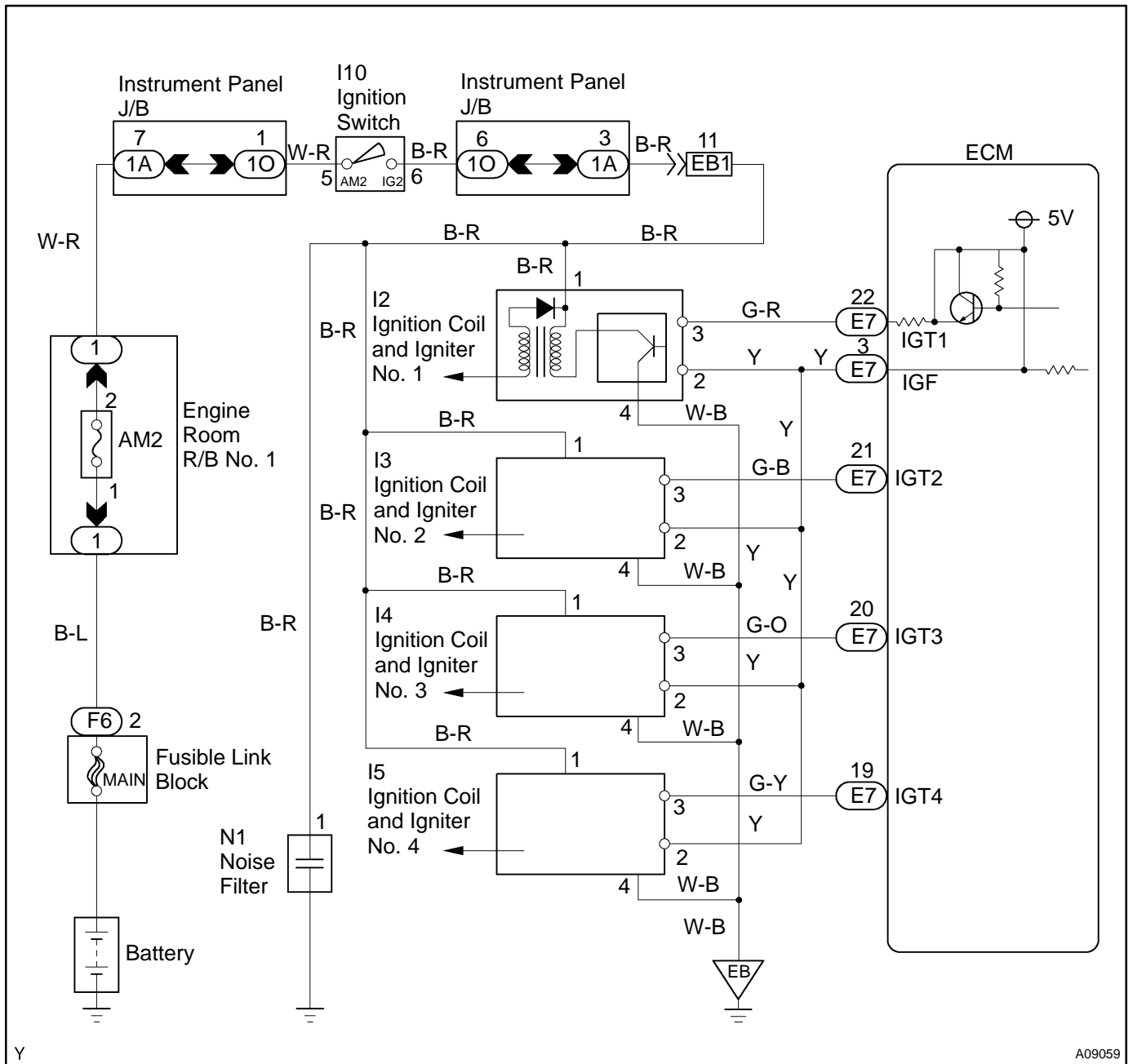

Y

A09059

## INSPECTION PROCEDURE

**HINT:**

- If DTC P1300 is displayed, check No.1 ignition coil with igniter circuit.
- If DTC P1305 is displayed, check No.2 ignition coil with igniter circuit.
- If DTC P1310 is displayed, check No.3 ignition coil with igniter circuit.
- If DTC P1315 is displayed, check No.4 ignition coil with igniter circuit.
- Read freeze frame data using TOYOTA hand-held tester or OBD II scan tool. Because freeze frame records the engine conditions when the malfunction is detected, when troubleshooting it is useful for determining whether the vehicle was running or stopped, the engine warmed up or not, the air-fuel ratio lean or rich, etc. at the time of the malfunction.

|          |                                                      |
|----------|------------------------------------------------------|
| <b>1</b> | <b>Check spark plug and spark (See page DI-63 ).</b> |
|----------|------------------------------------------------------|

|           |                      |
|-----------|----------------------|
| <b>NG</b> | <b>Go to step 4.</b> |
|-----------|----------------------|

|           |
|-----------|
| <b>OK</b> |
|-----------|

|          |                                                                                                                                                      |
|----------|------------------------------------------------------------------------------------------------------------------------------------------------------|
| <b>2</b> | <b>Check for open and short in harness and connector in IGF and IGT signal circuit between ECM and ignition coil with igniter (See page IN-29 ).</b> |
|----------|------------------------------------------------------------------------------------------------------------------------------------------------------|

|           |                                                |
|-----------|------------------------------------------------|
| <b>NG</b> | <b>Repair or replace harness or connector.</b> |
|-----------|------------------------------------------------|

|           |
|-----------|
| <b>OK</b> |
|-----------|

|          |                                                                                                                                  |
|----------|----------------------------------------------------------------------------------------------------------------------------------|
| <b>3</b> | <b>Disconnect ignition coil with igniter connector and check voltage between terminals IGF of ECM connector and body ground.</b> |
|----------|----------------------------------------------------------------------------------------------------------------------------------|

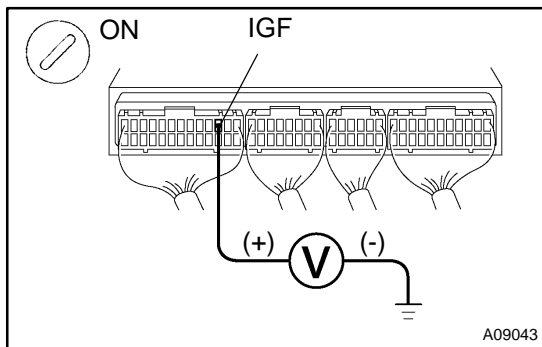

**PREPARATION:**

- Remove the connector cover from the ECM.
- Disconnect the ignition coil with igniter connector.
- Turn the ignition switch ON.

**CHECK:**

Measure voltage between terminals IGF of the ECM connector and body ground.

**OK:**

**Voltage: 4.5 - 5.5 V**

|           |                                            |
|-----------|--------------------------------------------|
| <b>OK</b> | <b>Replace ignition coil with igniter.</b> |
|-----------|--------------------------------------------|

|           |
|-----------|
| <b>NG</b> |
|-----------|

Check and replace ECM (See page [IN-29](#) ).

4 Check for open and short in harness and connector in IGT signal circuit between ECM and ignition coil with igniter (See page [IN-29](#) ).

NG

Repair or replace harness or connector.

OK

5 Check voltage between terminals IGT1 - 4 of ECM connector and body ground.

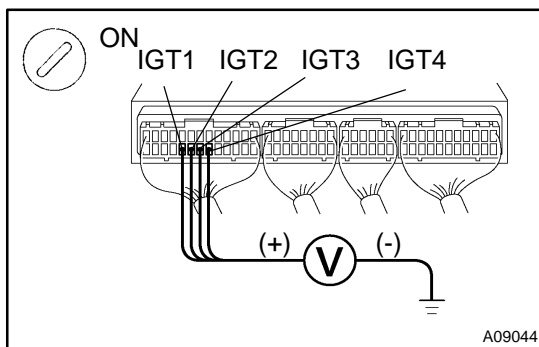

**PREPARATION:**

Remove the connector cover from the ECM.

**CHECK:**

Measure voltage between terminals IGT1 - 4 of the ECM connector and body ground when engine is cranked.

**OK:**

Voltage: More than 0.1 V and less than 4.5 V

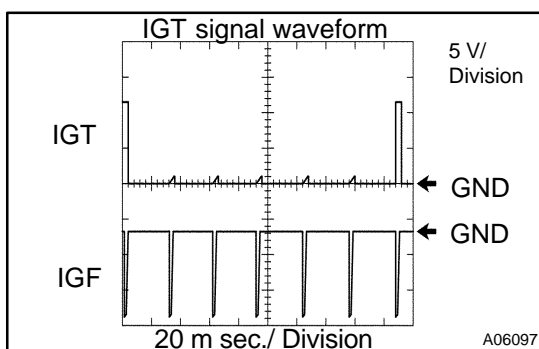

**Reference: INSPECTION USING OSCILLOSCOPE**

During cranking or idling, check waveform between terminals IGT1 - 4 and E1 of the ECM connector.

**HINT:**

Correct waveform appears as shown, with rectangle waves.

NG

Check and replace ECM (See page [IN-29](#) ).

OK

**6 Disconnect ignition coil with igniter connector and check voltage between terminals IGT1 - 4 of ECM connector and body ground.**

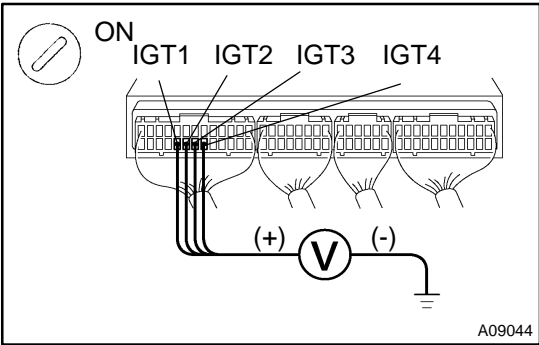

**PREPARATION:**

- (a) Remove the connector cover from the ECM.
- (b) Disconnect the ignition coil with igniter connector.

**CHECK:**

Measure voltage between terminals IGT1 - 4 of the ECM connector and body ground when engine is cranked.

**OK:**

**Voltage: More than 0.1 V and less than 4.5 V**

**NG** Check and replace ECM (See page [IN-29](#)).

**OK**

**7 Check ignition coil with igniter power source circuit.**

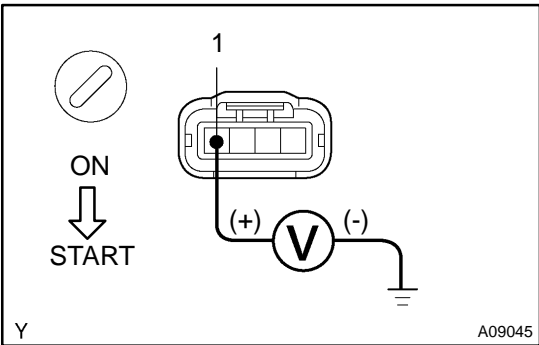

**PREPARATION:**

Disconnect the ignition coil with igniter connector.

**CHECK:**

Measure voltage between terminal 1 of ignition coil with igniter connector and body ground, when ignition switch is turned to "ON" and "START" position.

**OK:**

**Voltage: 9 - 14 V**

**NG** Repair ignition coil with igniter power source-circuit.

**OK**

**8 Check for open and short in harness and connector between ignition switch and ignition coil with igniter (See page [IN-29](#)).**

**NG** Repair or replace harness or connector.

**OK**

|          |                                                                               |
|----------|-------------------------------------------------------------------------------|
| <b>9</b> | <b>Check EFI main relay (Marking: EFI) (See page <a href="#">SF-47</a> ).</b> |
|----------|-------------------------------------------------------------------------------|

|           |                                               |
|-----------|-----------------------------------------------|
| <b>NG</b> | <b>Replace EFI main relay (marking: EFI).</b> |
|-----------|-----------------------------------------------|

|           |
|-----------|
| <b>OK</b> |
|-----------|

|                                            |
|--------------------------------------------|
| <b>Replace ignition coil with igniter.</b> |
|--------------------------------------------|