

## REASSEMBLY

### 1. A/T:

#### INSTALL OIL COOLER TO LOWER TANK

- (a) Install 2 new O-rings to the oil cooler.
- (b) Install the oil cooler to the lower tank.
- (c) Install the 2 plate washers and 2 nuts.

**Torque: 8.34 N-m (85 kgf-cm, 74 in.-lbf)**

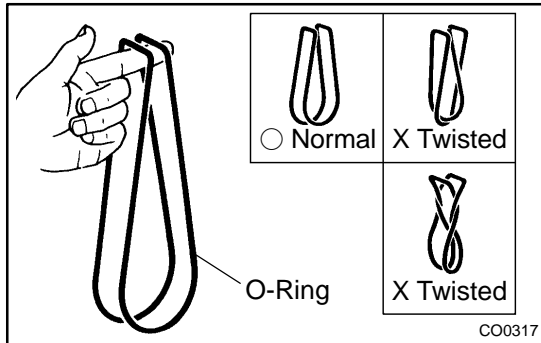

### 2. INSTALL NEW O-RINGS AND TANKS

- (a) After checking that there are no foreign objects in the lock plate groove, install the new O-ring without twisting it.

#### HINT:

When cleaning the lock plate groove, lightly rub it with sand paper without scratching it.

- (b) Install the tank without damaging the O-ring.

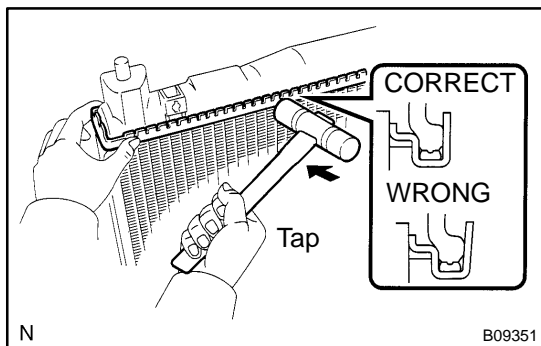

- (c) Tap the lock plate with a soft-faced hammer so that there is no gap between it and the tank.

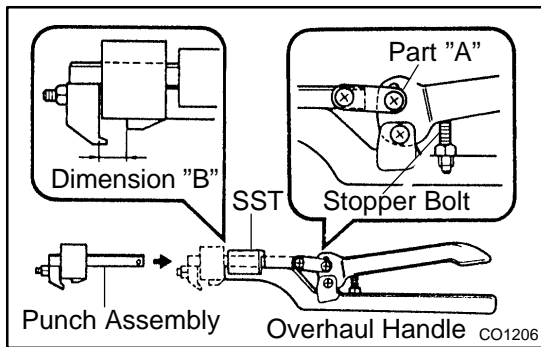

### 3. ASSEMBLE SST

SST 09230-01010, 09231-14010

- (a) Install the punch assembly to the overhaul handle, inserting it in the hole in part "A" as shown in the illustration.
- (b) While gripping the handle, adjust the stopper bolt so that dimension "B" is as shown in the illustration.

**Dimension: 8.4 mm (0.331 in.)**

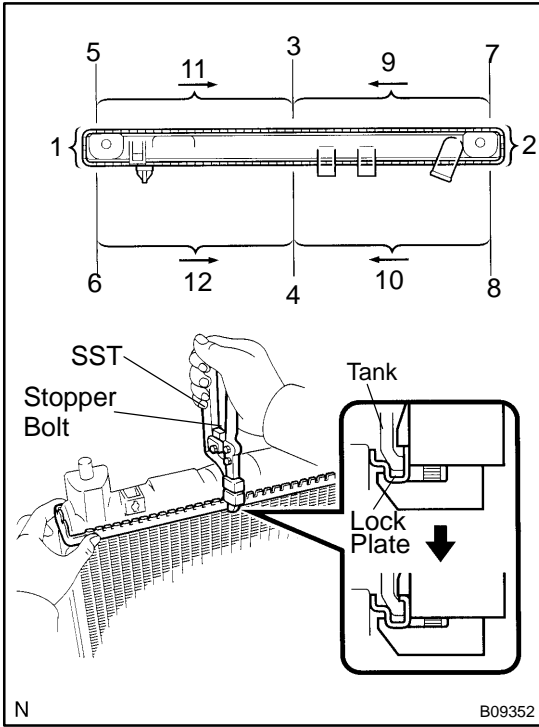

**4. CAULK LOCK PLATE**

(a) Lightly press SST against the lock plate in the order shown in the illustration. After repeating this a few times, stopped by the stopper plate.

SST 09230-01010

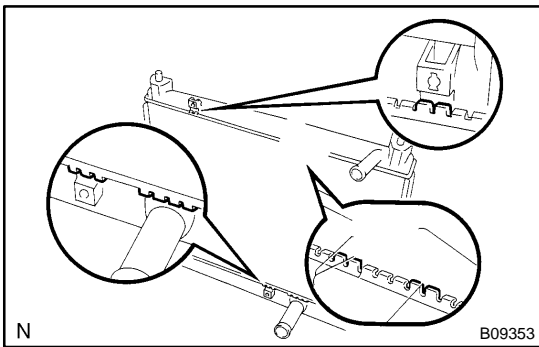

**HINT:**

- Do not stake the areas protruding around the pipes, brackets or tank rids.

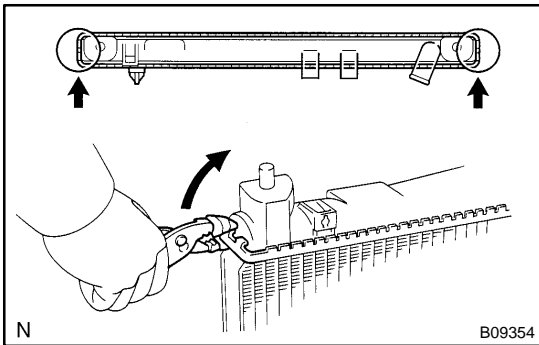

- The points shown in the illustration cannot be staked with SST. Use wrap vinyl tape around the tip of a pair or similar object and be careful not to damage the core plates.

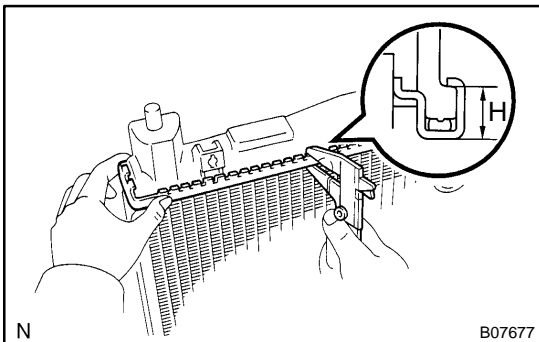

(b) Check the lock plate height (H) after completing the caulking.

**Plate height: 7.40 - 7.80 mm (0.2913 - 0.3071 in.)**

If not within the specified height, adjust the stopper bolt of the handle again and caulk again.

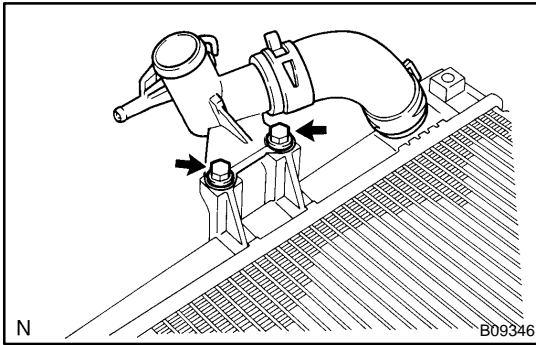
**5. INSTALL WATER FILER**

- (a) Install the water filler with the 2 bolts.  
**Torque: 7.5 N·m (76 kgf·cm, 66 in.-lbf)**
- (b) Connect the No. 3 radiator hose to the radiator.

**6. INSTALL DRAIN PLUG**

- (a) Install a new O-ring to the drain plug.
- (b) Install the drain plug.

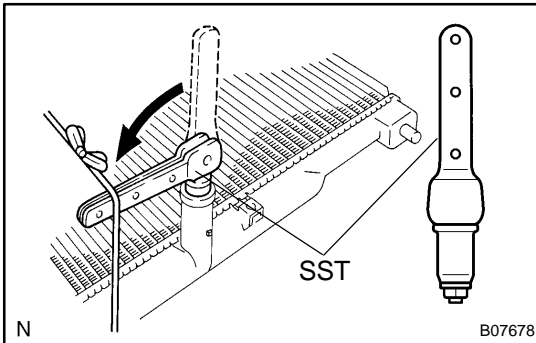
**7. INSPECT FOR WATER LEAKS**

- (a) Tighten the drain plug.
- (b) Plug the inlet and outlet pipes of the radiator with SST.  
SST 09230-01010
- (c) Using a radiator cap tester, apply pressure to the radiator.  
**Test pressure: 177 kPa (1.8 kgf/cm<sup>2</sup>, 26 psi)**
- (d) Submerge the radiator in water.

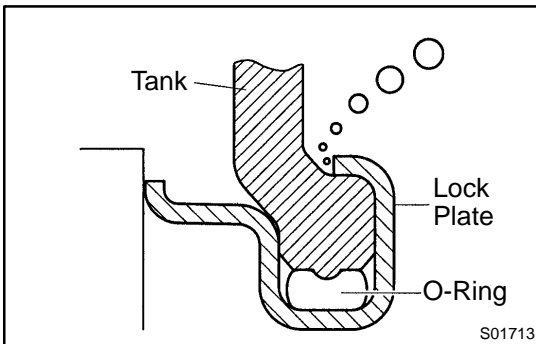

- (e) Inspect for leaks.

**HINT:**

On radiator with resin tank, there is a clearance between the tank and lock plate where a minute amount of air will remain, giving the appearance of an air leak when the radiator is submerged in water. Therefore, before doing the water leak test, first swish the radiator around in the water until all bubbles disappear.