

REASSEMBLY

1. **COAT PARTS WITH LITHIUM SOAP BASE GLYCOL GREASE, AS SHOWN**
2. **INSERT PISTON WITH SPRING INTO CYLINDER**
3. **INSTALL PUSH ROD AND BOOT**
 - (a) Install the washer to the push rod.
 - (b) Push the push rod to the piston, using snap ring pliers, install the snap ring.
 - (c) Install the boot.
4. **TEMPORARILY INSTALL LOCK NUT AND CLEVIS**

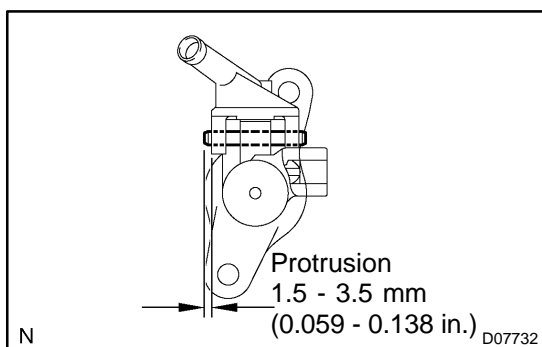

5. **INSTALL INLET UNION**
 - (a) Install the inlet union and a new grommet.
 - (b) Using a pin punch (3 mm) and hammer, drive in the slotted spring pin.