

INSPECTION

CAUTION:

Replace the seat belt assembly (outer belt, inner belt, bolts, nuts or sill-bar) if it has been used in a severe impact. The entire assembly should be replaced even if damage is not obvious.

1. RUNNING TEST (IN SAFE AREA)

- (a) Fasten the front seat belts.
- (b) Drive the car at 10 mph (16 km/h) and slam on the brakes. Check that the belt locks and cannot be extended at this time.

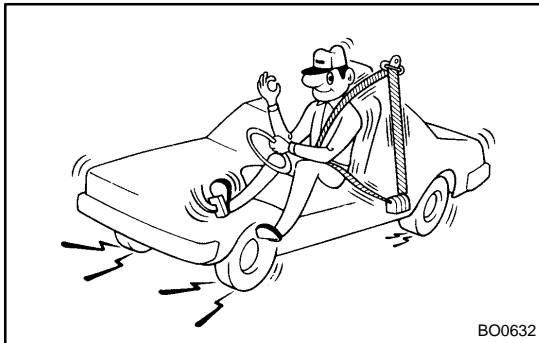

HINT:

Conduct this test in a safe area. If the belt does not lock, remove the belt mechanism assembly and conduct the following static check. Also, whenever installing a new belt assembly, verify the proper operation before installation.

2. ELR/ Driver's seat: STATIC TEST

- (a) Make sure that the belt locks when pulled out quickly.
- (b) Remove the locking retractor assembly.
- (c) Tilt the retractor slowly.

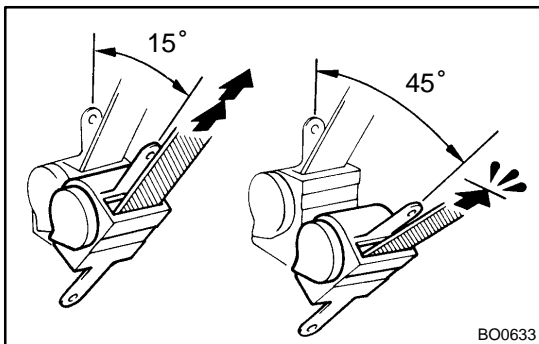

- (d) Make sure that the belt can be pulled out at a tilt of 15 degrees or less, and cannot be pulled out over 45 degrees of tilt.

If a problem is found, replace the assembly.

3. ELR, ALR/ Passenger's seat, Rear seat: STATIC TEST

- (a) Make sure that the belt locks when pulled out quickly.
- (b) Remove the locking retractor assembly.
- (c) Pull out the whole belt and measure the length of the whole belt.

Then retract the belt slightly and pull it out again.

- (d) Make sure that the belt cannot be extended further.
- If a problem is found, replace the assembly.

BODY - SEAT BELT

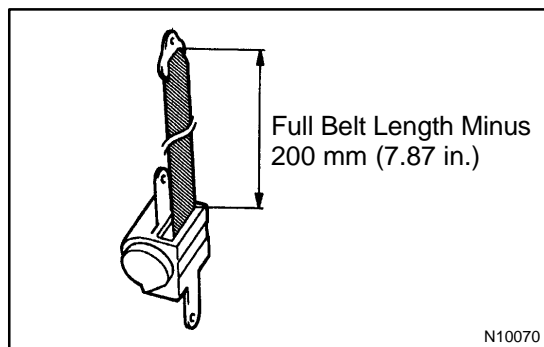

- (e) Retract the whole belt, then pull out the belt until 200 mm (7.87 in.) of belt remains retracted.
- (f) Tilt the retractor slowly.

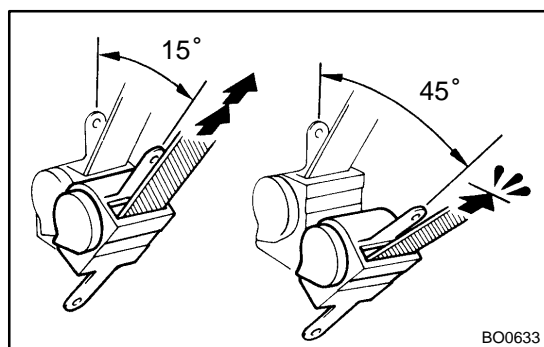

- (g) Make sure that the belt can be pulled out at a tilt of 15 degrees or less, and cannot be pulled out at over 45 degrees of tilt.

If a problem is found, replace the assembly.